

MR Passenger Elevator

Hoistway Structure

Concrete Brick & Concrete Other

Unstandard Standard

NOTE

				Technical Requirement:			
HW	HOISTWAY WIDTH	CW	CAR INSIDE WIDTH	Type	TKJ1000/1.0 -VF		
HD	HOISTWAY DEPTH	CD	CAR INSIDE DEPTH	F/P/D	/ /	Door type	Center open
OP	DOOR OPENING WIDTH	CH	CAR HEIGHT	load	1000 kg	speed	1.0 m/s
ROP	WALL OPENING WIDTH	MRW	MACHINE ROOM WIDTH	Machine	MCK200	Roping	2 : 1
OPH	DOOR OPENING HEIGHT	MRD	MACHINE ROOM DEPTH	T/sheave	φ 400	D/sheave	φ 400
OH	OVERHEAD HEIGHT	MRH	MACHINE ROOM HEIGHT	car sheave	φ 400	CW sheave	φ 400
CAR DBG	DISTANCE BETWEEN CAR GUIDE RAILS			Shaft	HW 2200 mm x HD 2000 mm		
CWT DBG	DISTANCE BETWEEN COUNTERWEIGHT GUIDE RAILS			Cabin	CW 1600 mm x CD 1400 mm		
				Door	OP 900 mm x OPH 2100 mm		

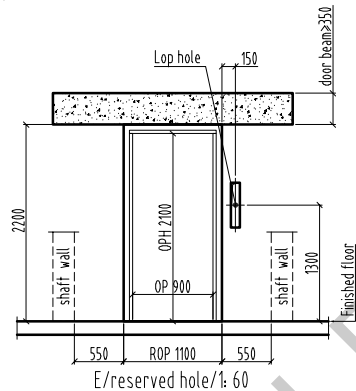
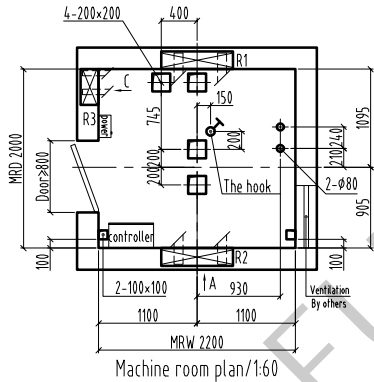
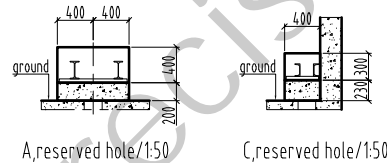

Bottom box Lop: 100x500 (base station) 100x400 (remaining stations)
No bottom box Lop hole: φ50 hole

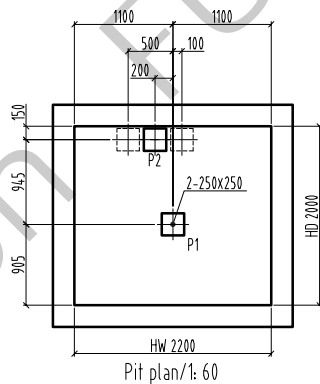
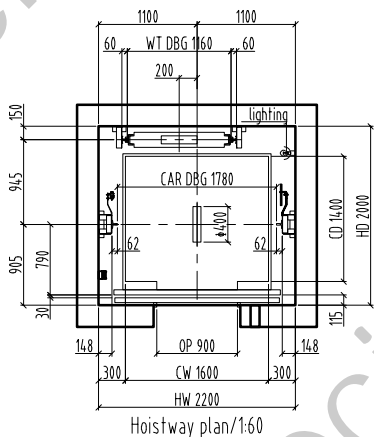

When $v \leq 1.0$ m/s, $H \leq 30$; when 1.0 m/s $< v \leq 1.75$ m/s, $H \leq 80$; when the lifting height is more than 35m, the buffer pier P2 is arranged according to the dotted line, the bearing capacity is pressed A single P2/2 calculation.

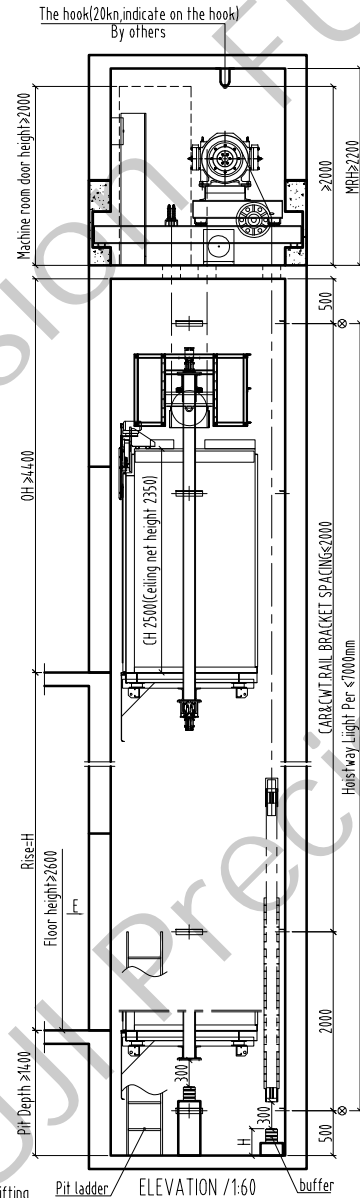

OH	≥4.00
Rise	H
26 F	
25 F	
24 F	
23 F	
22 F	
21 F	
20 F	
19 F	
18 F	
17 F	
16 F	
15 F	
14 F	
13 F	
12 F	
11 F	
10 F	
9 F	
8 F	
7 F	
6 F	
5 F	
4 F	
3 F	
2 F	
1 F	
GF	
B F	
Pit	≥1400
Floor	Height

FTK 1000-01-

approver

Project name

manufacturing no.

Drawing No.

Drawing

FTK 1000-01-

approver

Project name

manufacturing no.

Drawing No.

Drawing

FTK 1000-01-

approver

Project name

manufacturing no.

Drawing No.

Drawing

FTK 1000-01-

approver

Project name

manufacturing no.

Drawing No.

Drawing

FTK 1000-01-

approver

Project name

manufacturing no.

Drawing No.

Drawing

FTK 1000-01-

approver

Project name

manufacturing no.

Drawing No.

Drawing

FTK 1000-01-

approver

Project name

manufacturing no.

Drawing No.

Drawing

FTK 1000-01-

approver

Project name

manufacturing no.

Drawing No.

Drawing

FTK 1000-01-

approver

Project name

manufacturing no.

Drawing No.

Drawing

FTK 1000-01-

approver

Project name

manufacturing no.

Drawing No.

Drawing

FTK 1000-01-

approver

Project name

manufacturing no.

Drawing No.

Drawing

FTK 1000-01-

approver

Project name

manufacturing no.

Drawing No.

Drawing

FTK 1000-01-

approver

Project name

manufacturing no.

Drawing No.

Drawing

FTK 1000-01-

approver

Project name

manufacturing no.

Drawing No.

Drawing

FTK 1000-01-

approver

Project name

manufacturing no.

Drawing No.

Drawing

FTK 1000-01-

approver

Project name

manufacturing no.

Drawing No.

Drawing

FTK 1000-01-

approver

Project name

manufacturing no.

Drawing No.

Drawing

FTK 1000-01-

approver

Project name

manufacturing no.

Drawing No.

Drawing

FTK 1000-01-

approver

Project name

manufacturing no.

Drawing No.

Drawing

FTK 1000-01-

approver

Project name

manufacturing no.

Drawing No.

Drawing

FTK 1000-01-

approver

Project name

manufacturing no.

Drawing No.

Drawing

FTK 1000-01-

approver

Project name

manufacturing no.

Drawing No.

Drawing

FTK 1000-01-

approver

Project name

manufacturing no.

Drawing No.

Drawing

FTK 1000-01-

approver

Project name

manufacturing no.

Drawing No.

Drawing

FTK 1000-01-

approver

Project name

manufacturing no.

Drawing No.

Drawing

FTK 1000-01-

approver

Project name

manufacturing no.

Drawing No.

Drawing

FTK 1000-01-

approver

Project name

manufacturing no.

Drawing No.

Drawing

FTK 1000-01-

approver

Project name

manufacturing no.

Drawing No.

Drawing

FTK 1000-01-

approver

Project name

manufacturing no.

Drawing No.

Drawing

FTK 1000-01-

approver

Project name

manufacturing no.

Drawing No.

Drawing

FTK 1000-01-

approver

Project name

manufacturing no.

Drawing No.

Drawing

FTK 1000-01-

approver

Project name

manufacturing no.

Drawing No.

Drawing

FTK 1000-01-

approver

Project name

manufacturing no.

Drawing No.

Drawing

FTK 1000-01-

approver

Project name

manufacturing no.

Drawing No.

Drawing

FTK 1000-01-

approver

Project name

manufacturing no.

Drawing No.

Drawing

FTK 1000-01-

approver

Project name

manufacturing no.

Drawing No.

Drawing

FTK 1000-01-

approver

Project name

manufacturing no.

Drawing No.

Drawing

FTK 1000-01-

approver

Project name

manufacturing no.

Drawing No.

Drawing

FTK 1000-01-

approver

Project name

manufacturing no.

Drawing No.

Drawing

FTK 1000-01-

approver

Project name

manufacturing no.

Drawing No.

Drawing

FTK 1000-01-

approver

Project name

manufacturing no.

Drawing No.

Drawing

FTK 1000-01-

approver

Project name